

[CONTRIBUTION FROM THE COBB CHEMICAL LABORATORY, UNIVERSITY OF VIRGINIA]

**EQUILIBRIUM IN THE REACTION, $\text{NiO} + \text{H}_2 \rightleftharpoons \text{Ni} + \text{H}_2\text{O}$.
THE FREE ENERGY OF NICKELOUS OXIDE**

BY ROBERT N. PEASE AND ROY S. COOK

RECEIVED JANUARY 20, 1926

PUBLISHED MAY 5, 1926

Published data which might be utilized for a calculation of the free energy of formation of nickelous oxide are rather unsatisfactory. Foote and Smith¹ have made a preliminary determination of the oxygen pressure over nickelous oxide at 1000° to 1200°, but the solid phases were not examined. Chaudron² and Wöhler and Balz³ have measured the steam-hydrogen ratio in the reaction, $\text{NiO} + \text{H}_2 \rightleftharpoons \text{Ni} + \text{H}_2\text{O}$. Both investigators used the classical Deville method of circulating water vapor, saturated at room temperature, over the charge and measuring the increase in pressure due to formation of hydrogen. Chaudron reports no hydrogen obtained at 1100°, while Wöhler and Balz report a steam-hydrogen ratio of 15 at 450°. The latter corresponds to a pressure increase of less than 1 mm. of mercury in an experiment by the Deville method. It was not determined whether this was actually due to hydrogen or to the release of occluded gases. The quantity is in any case so uncertain that little confidence can be placed in the result, as the authors point out in comparing the result with that obtained from cobalt oxide, which was much the same.

Since the steam-hydrogen ratio over the system iron-ferrous oxide is of the order of unity and since indirect evidence indicates that over the system copper-cupric oxide the constant would be infinitely great (copper is not measurably oxidized by steam), one looks for a relatively large constant for the system nickel-nickelous oxide. For cobalt-cobaltous oxide a value in the neighborhood of 15 is not entirely unexpected.

As the necessity for further work on nickelous oxide appeared clear and as we were especially interested in the reaction, $\text{NiO} + \text{H}_2 \rightleftharpoons \text{Ni} + \text{H}_2\text{O}$, we have undertaken new measurements of equilibrium in this reaction. Instead of using the Deville method, we have preferred to pass steam or hydrogen, or a mixture of the two, at atmospheric pressure over charges which were originally nickel or the oxide and to collect and measure the products. In this way we have determined the position of equilibrium over a charge which was in the one case chiefly nickel and in the other chiefly nickelous oxide, at 485° and 600°.

Apparatus and Method

Fig. 1 is a sketch of the apparatus. It consisted of an electrolytic

¹ Foote and Smith, *THIS JOURNAL*, **30**, 1348 (1908).

² Chaudron, *Ann. chim.*, **16**, 244 (1921).

³ Wöhler and Balz, *Z. Elektrochem.*, **27**, 406 (1921).

hydrogen generator, a steam generator, the tube containing the charge, a water-cooled gas buret and an electric furnace.

The hydrogen was generated electrolytically in cells with nickel wire electrodes and a concd. sodium hydroxide solution as electrolyte. It was passed over hot, platinized asbestos and through phosphorus pentoxide for purification. The latter was discarded in the later runs since the hydrogen passed directly through the steam generator. Steam was generated in a 500cc. distilling flask, the neck of which was drawn down and sealed to the apparatus. The flask was heavily coated with magnesia pipe covering. It was heated from below by a small electric crucible furnace. The rate of steam flow was controlled by means of the current through this furnace. The water was always boiled before introduction into the steam generator and was introduced hot, care being taken to exclude air.

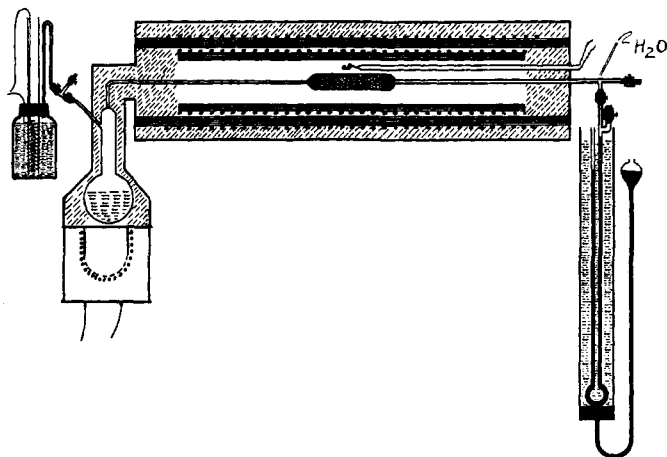

Fig. 1.—Apparatus.

The tube containing the charge was heated in a horizontal electric furnace 76 cm. long. An iron pipe 5 cm. in diameter was wound with Nichrome ribbon. This was inserted in an Alundum tube which also was wound with Nichrome ribbon. The latter was covered with a section of magnesia pipe covering. The ends were filled with a paste of the latter material. Temperatures were read on a nitrogen-filled thermometer or a single-junction base-metal thermocouple.

Nickelous oxide was prepared by precipitation from a solution of c. p. cobalt-free nickel nitrate. A 2.5% solution of the latter was slowly added in slight excess to a 2.5% solution of sodium hydroxide with constant stirring. The precipitate was washed five times, with 20 liters of water each time, filtered off and dried. The filter-cake was broken up and dried at 450° in air. This gave shiny, black, coherent granules of the oxide, about 50 g. of which was used in each experiment. This amount was contained in a Pyrex tube 2.5 cm. in diameter and 15–20 cm. long, to the ends of which was sealed 6 mm. tubing.

Steam-hydrogen mixtures of various compositions and at various rates were passed over charges originally consisting of nickelous oxide, or of nickel prepared therefrom by reduction. The effluent mixture passed into a water-jacketed gas buret, the stem of which was water-cooled to condense the steam. During the collection, great care was taken to maintain atmospheric pressure within the system by lowering the leveling bulb steadily, keeping the mercury levels in the buret and in the open side-arm the same. When a buret full of hydrogen and water had been collected the buret was cut off and the effluent mixture passed out to the air. The volumes of hydrogen and liquid water collected were then read off, the temperature and pressure being noted. The pressure was corrected for the vapor pressure of water. The volume of steam corresponding to the water collected was then calculated to the temperature and pressure of the hydrogen. The value of the steam-hydrogen ratio of the entering gas was calculated from the total of effluent steam and the rate of introduction of hydrogen as fixed by the reading of the ammeter in series with the hydrogen generator.

Preliminary Observations

In order to make certain that our material was actually nickelous oxide, samples were heated to 400–500° in a current of air or oxygen, weighed and reduced by hydrogen. The total water obtained was measured (the latter part by absorption in calcium chloride) and the charge was again weighed, air being excluded. The calculated percentage of oxygen in nickelous oxide is 21.43%. One sample gave 21.35% from the loss in weight and 21.48% from the weight of water formed. Another gave 21.69% from the loss in weight and 21.80% from the water formed.

One sample of oxide was reduced completely and the residue steamed continuously for 240 hours at 500° in order to demonstrate that hydrogen could be thus obtained in quantity, and to get a value for the composition of oxide so formed. In this way, several hundred cubic centimeters of hydrogen was collected at different times, the ratio of hydrogen to steam being roughly 1 to 250. After steaming, the oxide was reduced in hydrogen, and water corresponding to an oxygen content of 17.36% was collected. Since hydrogen was still being slowly evolved at the end of the 240-hour period, oxidation was not complete. The indication is that the steaming forms nickelous oxide (the oxygen content being equal to 21.43%).

Another sample of oxide was treated with steam at 500° to determine if it could be thus converted to a higher oxide. No hydrogen was obtained, indicating that no oxidation took place.

One sample of reduced nickel was oxidized by air overnight at 500°. On complete reduction it gave an amount of water equivalent to approxi-

mately 80% of the nickelous oxide formed. This sample, on reduction, behaved exactly like a sample of the original oxide. The indication is that the oxide formed by air-oxidation is nickelous oxide.

Another sample was treated with steam and oxygen. No absorption took place, as much oxygen passing through as was introduced. It may be concluded from these results that no oxide of higher oxygen content than that of nickelous oxide is involved in these experiments.

It was found that when the charge was pure oxide, nearly all of the entering hydrogen was at first consumed from a steam-hydrogen mixture; and starting similarly with pure metal and steam, the effluent hydrogen was always at first excessively high, that is to say, the pure solid phases are the more reactive. Eventually, however, the two values came together. When pure hydrogen was passed over nickelous oxide this behavior was greatly accentuated. Indeed, certain charges consumed practically all of the entering hydrogen until reduction was more than half complete and then "broke" suddenly, giving no indication of a halt at the equilibrium value.

In Run 3-7-2, a 150:1 steam-hydrogen mixture at 150 cc. per minute was passed through a charge of 84 g. of nickelous oxide at 485°. During the first 20 hours, no hydrogen at all was collected. At the end of 25 hours, the effluent mixture had the composition, 1100 parts of steam and one part of hydrogen. This dropped to 333 parts of steam and one of hydrogen at 29.5 hours, and was constant thereafter. In Run 4-1-1, 45 g. of nickelous oxide from another batch passed a little hydrogen from the start under the same conditions and the steam-hydrogen ratio dropped to 350 after 4.7 hours. This sample proved to be less active on "straight" reduction and was considerably more dense.

The sample of oxide used in Run 3-7-2 was completely reduced and treated with steam at 100 cc. per minute at 485°. After one hour, the steam-hydrogen ratio was 250; it was 305 after 12.6 hours. The ratios at 48, 73.5 and 221 hours were 337, 338 and 345, respectively. The halt at a ratio approximately 335 was marked. After this, less hydrogen was obtained, presumably because of failure to reach equilibrium. The nickel obtained from Run 4-1-1 behaved in a similar manner, except that the ratio reached a value of 330 after 12.9 hours.

Analogous results have been obtained with iron oxides by Richardson, Vibrans and Bell.⁴ In "the first stages of both reducing and steaming higher conversion of steam to hydrogen and higher conversion of reducing gases to oxidized gases have been obtained than the equilibrium data indicate to be possible."

In the case of iron oxide the variation in the equilibrium constant, when the solid phase consists chiefly of one or other pure constituent, has been

⁴ Richardson, Vibrans and Bell, *Science*, 56, 27 (1922).

ascribed by Eastman⁵ to the formation of solid solutions. There is little doubt that the changes in the equilibrium constant are due to some gradual change in the nature of the solid phases which shortly reaches a limit. Solid solutions of limited composition-range offer one possibility of explanation. Another possibility is, in its simplest terms, that it is futile to talk of an equilibrium involving two solid phases until both are present. At the start of an experiment there is only the one phase. The second is gradually formed as reaction proceeds. What is found experimentally is that the consumption of gaseous reactant required for the introduction of this new phase is excessively high. We know from other work that the free energy of a solid phase depends upon its dimensions when these are small. In this example, the results are to be expected if the free energies of formation of thin films of oxide on metal and of metal on oxide are higher than those of the oxide and metal, respectively, in the massive state.

Equilibrium Measurements

From the preliminary runs of Tables I and II it is clear that the equilibrium ratio of steam to hydrogen lies between 300 and 350 at 485°. In order to fix the point more precisely, experiments were next carried out in which an 85g. sample of nickelous oxide, prepared by air-oxidation of a reduced nickel, was treated with a steam-hydrogen mixture for about 50 hours at 450-500°. Readings were then taken when mixtures of various compositions were introduced at varying rates. The results are given in Table I.

TABLE I
EQUILIBRIUM FROM THE NICKELOUS OXIDE SIDE AT 485°^a
RUN 3-7-8

Cc. introduced per min. Steam	Hydrogen	Cc. collected		H ₂ O/H ₂	
		Water (liq.)	Hydrogen	In	Out
140	0.60	3.95	18.45	235	308
190	.80	4.60	19.15	240	345
165	.80	4.00	17.25	205	333
165	.80	4.00	18.60	205	308
125	.60	3.50	16.75	210	300
185	.60	3.85	17.65	310	313
120	.40	3.75	16.30	300	330
145	.40	3.55	15.60	365	326
195	.40	4.05	16.80	490	346
220	.60	3.80	16.10	365	339
190	.60	3.30	14.45	315	328
120	.60	4.15	19.40	200	307

^a The temperature of the furnace was 485°, that of the buret 27°, and the barometric reading was 750 mm.

Having regard for the amount of change in the ratio in the various

⁵ Eastman, *THIS JOURNAL*, **44**, 975 (1922). Eastman and Evans, *ibid.*, **46**, 888 (1924).

experiments, it seems that a value of the steam-hydrogen ratio close to $325 \approx 5$ could not be far from the truth.

The charge was then completely reduced by hydrogen and a steam-hydrogen mixture passed over it for 72 hours. Readings were then begun. The results are given in Table II.

TABLE II
EQUILIBRIUM FROM THE NICKEL SIDE AT 485° ^a
RUN 3-7-9

Cc. introduced per min. Steam	Hydrogen	Cc. collected		$\text{H}_2\text{O (vapor)/H}_2$	
		Water (liq.)	Hydrogen	In	Out
265	0.0	4.55	17.60		378
155	.40	4.30	17.10	390	368
180	.40	4.90	19.80	450	362
205	.80	4.90	20.95	260	342
205	.80	4.95	20.95	260	345
170	.80	4.70	19.80	210	346
150	.80	4.65	20.00	190	340
130	.60	4.95	21.90	215	330
150	.60	4.60	20.75	250	324
135	.60	4.65	20.65	225	328
150	.40	4.15	18.35	375	330
125	.40	4.35	19.20	310	330

^a The temperature of the furnace was 485° , that of the buret 30° , and the barometric reading was 750 mm.

From these results it is concluded that the ratio $\text{H}_2\text{O}/\text{H}_2 = 335 \approx 5$.

The temperature was then raised to 600° and further readings were taken. These are set forth in Table III.

TABLE III
EQUILIBRIUM FROM THE NICKEL SIDE AT 600° ^a

Cc. introduced per min. Steam	Hydrogen	Cc. collected		$\text{H}_2\text{O}/\text{H}_2$	
		Water (liq.)	Hydrogen	In	Out
115	0.80	2.80	21.60	145	189
145	.80	2.95	21.30	180	202
190	.80	3.25	20.70	240	229
250	.80	3.45	21.45	315	234
200	.80	3.45	22.05	250	228
160	.80	3.25	20.65	200	230
130	.80	3.50	21.75	165	235

^a The temperature of the furnace was 600° , that of the buret 30° , and the barometer reading was 750 mm.

The equilibrium value of the steam-hydrogen ratio as derived from these results is $230 \approx 5$.

The charge was then oxidized with air overnight at 500° , after which time a steam-hydrogen mixture was passed through for 48 hours at about 600° . Readings were then taken. (See Table IV.)

TABLE IV
EQUILIBRIUM FROM THE NICKELOUS OXIDE SIDE AT 600°*

Cc. introduced per min. Steam	Hydrogen	Cc. collected		H ₂ O/H ₂	
		Water (liq.)	Hydrogen	In	Out
165	1.0	3.35	19.70	165	248
235	1.0	2.40	14.60	235	240
170	1.0	2.95	16.90	170	255
170	0.60	2.95	17.45	285	246
100	.40	3.10	18.05	250	251
170	.40	2.95	17.10	425	252
215	1.0	2.95	17.10	215	252

* The temperature of the furnace was 600°, that of the buret 30°, and the barometric reading was 750 mm.

From this last set of readings it is estimated that the equilibrium value of the steam-hydrogen ratio is 250 ± 5 .

These four series of equilibrium measurements are summarized in Table V.

TABLE V
SUMMARY OF TABLES I, II, III AND IV

Temperature °C.	Abs.	Character of charge	H ₂ O/H ₂ equil.	Average H ₂ O/H ₂
485	758	NiO from air-oxidation of Ni, about 5% reduced.	325	
485	758	Ni from reduction of NiO, about 10% oxidized.	335	330 ± 10
600	873	Same as above.	230	
				240 ± 10
600	873	NiO from air-oxidation of Ni, partially reduced.	250	

These results seem to give sufficient proof that the equilibrium is between NiO-Ni-H₂-H₂O. The same end-point is reached starting from either nickel or nickelous oxide, whether hydrogen or water is in excess.

Free Energy of the Reaction $\text{NiO} + \text{H}_2 \rightleftharpoons \text{Ni} + \text{H}_2\text{O}$

Since there are no data on the heat capacity of nickelous oxide and the reaction is one in which there is no change in the number of molecules, it has seemed best not to introduce heat capacity terms. The free energy equation then becomes $\Delta F = -RT \ln K = \Delta H + IT$. Substituting the average values at 485° and 600°, one obtains, $\Delta F_{758} = -4.579 \cdot 758 \log 330 = -8742 = \Delta H + I 758$; $\Delta F_{873} = -4.579 \cdot 873 \log 240 = -9515 = \Delta H + I 873$. $\Delta H = -3647$; $I = -6.722$; $\Delta F = -3647 - 6.722T$. This is for the reaction $\text{NiO} + \text{H}_2 \rightleftharpoons \text{Ni} + \text{H}_2\text{O}_{(v)}$. $\Delta F_{298} = -5651$ cal. There have been two determinations of the heat of formation of nickelous oxide. Mixer⁶ gives the value +57,900 cal., while Ruff and Gersten⁷ found $51,500 \pm 700$ cal. Taking the heat of formation of water

⁶ Mixer, *Am. J. Arts, Sci.*, [4] 30, 193 (1910).

⁷ Ruff and Gersten, *Ber.*, 46, 400 (1913).

vapor to be +57,800 cal., these values give for ΔH , +100 cal. and -6300 cal., respectively. Our value of ΔH (-3647 cal.) is to be compared with these.

At 450°, $K = 350$, which is to be compared with Wöhler and Balz' value of 15. At 1100°, the constant is about 110. If this is correct, it is quite understandable that Chaudron could detect no hydrogen. With a water-vapor pressure of 15 mm., the partial pressure of hydrogen at equilibrium would be about 0.14 mm.

Free Energy of Nickelous Oxide

By combination of the equations for the free energy of the reaction under discussion and that for the water vapor, an equation for the free energy of formation of nickelous oxide may be obtained. $\text{NiO} + \text{H}_2 \rightleftharpoons \text{Ni} + \text{H}_2\text{O}_{(v)}$; $\Delta F = -3647 - 6.722T$; $\text{H}_2 + \frac{1}{2}\text{O}_2 \rightleftharpoons \text{H}_2\text{O}_{(v)}$; $\Delta F = -57,410 + 0.94 T \ln T + 0.00165T^2 - 0.0637T^3 + 3.92T$; $\text{Ni} + \frac{1}{2}\text{O}_2 \rightleftharpoons \text{NiO}$; $\Delta F = -53,763 + 0.94 T \ln T + 0.00165T^2 - 0.0637T^3 + 10.64T$; $\Delta F_{298} = -56,497$ cal.

At 1100°, Foote and Smith obtained an oxygen pressure of 5.5 mm. over nickelous oxide. The above equation gives $\Delta F_{1373} = -\frac{1}{2}RT \ln \frac{1}{p_{\text{O}_2}} = 27,675$ cal., whence $p_{\text{O}_2} = 10^{-6}$ mm., which is of another order of magnitude.

Summary

The reaction, $\text{NiO} + \text{H}_2 \rightleftharpoons \text{Ni} + \text{H}_2\text{O}$, has been quantitatively studied and the position of equilibrium has been measured at 485° and 600°, by a flow method. Equilibrium was approached from both sides. The equilibrium ratios, $\text{H}_2\text{O}/\text{H}_2$, were found to be 330 at 485°, and 240 at 600°. These have been compared with related data to be found in the literature, and free energies have been calculated.

Attention is called to the observations which indicate that excessively high yields of gaseous products are obtained in the early stages of both reduction and oxidation. This is accounted for if the free energies of a film of metal on oxide and of oxide on metal are higher than those of metal and oxide, respectively, in the massive state.

UNIVERSITY, VIRGINIA